

## User Handbook

# POWER SPRING STARTERS SZH2SS/SZH2SR Models

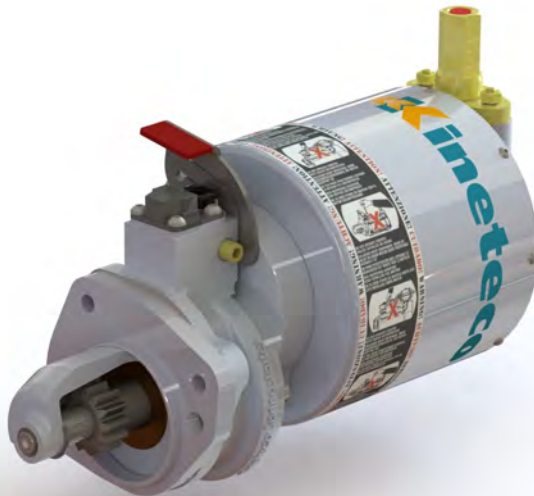

---

Kineteco Spring Starters are the sole product of  
Hatraco Technische Handelsonderneming B.V.  
and are manufactured in The Netherlands

---

# Contents

Page No.

3	Introduction
3	Your Spring Starter
4	Assembling the Winding Handle
5	Pre-Installation Checks
8	Fitting the Spring Starter
9	Engine 'Walk Over' to Check Pinion Engagement
11	Starting for the First Time
12	Standard Starting Procedure
12	Unwinding the Spring Starter
13	E-Pack Installation Guide
14	Troubleshooting
15	Warranty Terms
16	General Terms & Conditions



## WARNING

Failure to install or operate the spring starter correctly as described in this handbook will invalidate the warranty



## 1. Introduction

The following pages of this handbook should be worked through in sequence. This will ensure the spring starter is correctly set up for the engine it is to be fitted to, and the user will have a full understanding of the safe and reliable operation of the spring starter.

Allow at least 30 minutes to follow these instructions step-by-step to ensure correct operation.

If there are any queries about your spring starter that are not explained in the handbook, please get in touch with Kineteco via the contacts at the bottom of the page.

Once the handbook has been used to setup, install and operate the spring starter for the first time, please keep it in a safe place for future reference.

## 2. Your Spring Starter

Please take a moment to familiarise yourself with the features of the product shown in Fig 1. The instructions contained in this handbook will use these descriptions.

Fig 1

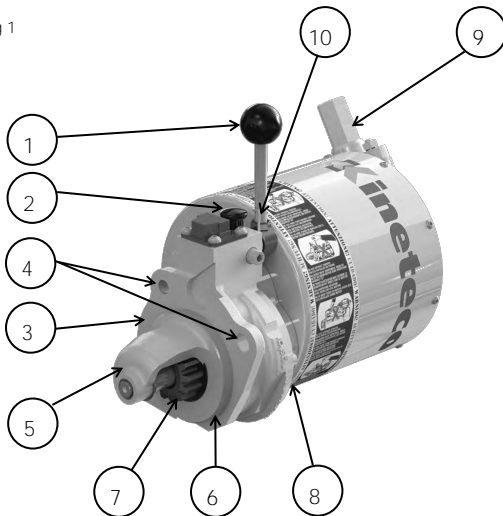

Number	Description
1	Trip lever
2	Release pin
3	Mounting flange
4	Mounting holes
5	Nosepiece
6	Spigot
7	Pinion gear
8	Z-Drive gearbox
9	Winding adaptor
10	Torsion spring

(Exact configuration will vary)



### WARNING

Never operate the starter when not correctly installed on an engine

### 3. Assembling the Winding Handle

Your spring starter comes supplied with a winding handle that needs to be assembled before use.

Please follow instructions below:

- a. Fit male square drive of sleeve into crank handle as shown in Fig 2i
- b. Screw together with supplied M10 bolt, spring washer and plain washer in order shown in Fig 2i, tighten with 17mm spanner, to result in completed assembly as shown in Fig 2ii

Fig 2i

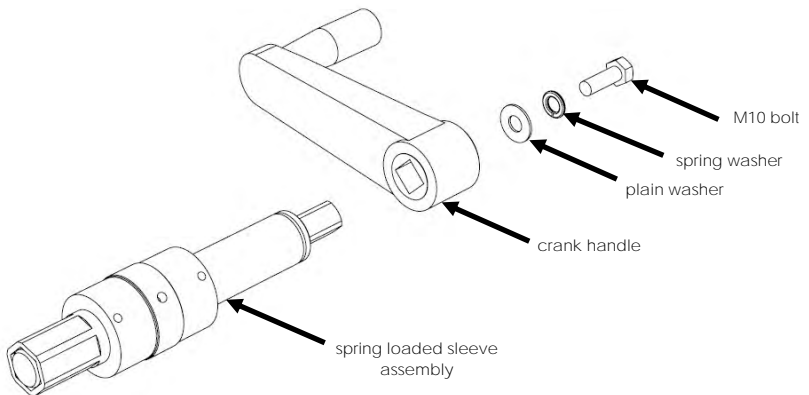
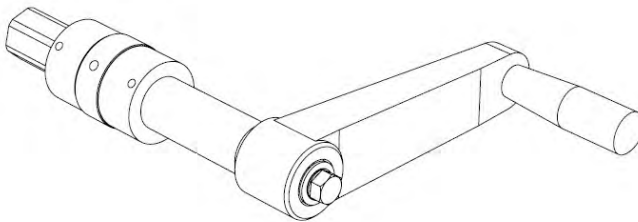

Fig 2ii



#### 4. Pre-Installation Checks

Before installing or using the spring starter the following checks should be made.

These checks will determine whether the starter rotates in the correct direction for the engine it is to be fitted to; whether the pinion will have enough clearance from the engine's ring gear; and lastly whether the pinion engages correctly with the ring gear.

It is very important to make these checks before using the spring starter. If the starter is not correctly matched to the engine, the spring starter, engine, or both, could be damaged.

If at any stage of these checks the spring starter does not appear to be correct, please contact Kineteco immediately where our trained technical staff will be able to help with any issues.

a. To check that the spring starter will rotate the engine in the correct direction, check the spring starter model number:

- An 'SZH2SS' starter pinion rotates clockwise viewed from pinion end
- An 'SZH2SR' starter pinion rotates anti-clockwise viewed from pinion end

On an engine where the starter fits along the side of the engine block as per Fig 3i, an SZH2SS starter rotates the flywheel anti-clockwise viewed from the flywheel end. An SZH2SR starter rotates the flywheel clockwise viewed from the flywheel end

Fig 3i

- b. Next, check the pinion's clearance from the ring gear. Cut out the card gauge from the back page of this handbook following the dashed lines
- c. Measure the 'flange to ring gear' dimension A, as shown in Fig 3ii

Fig 3ii

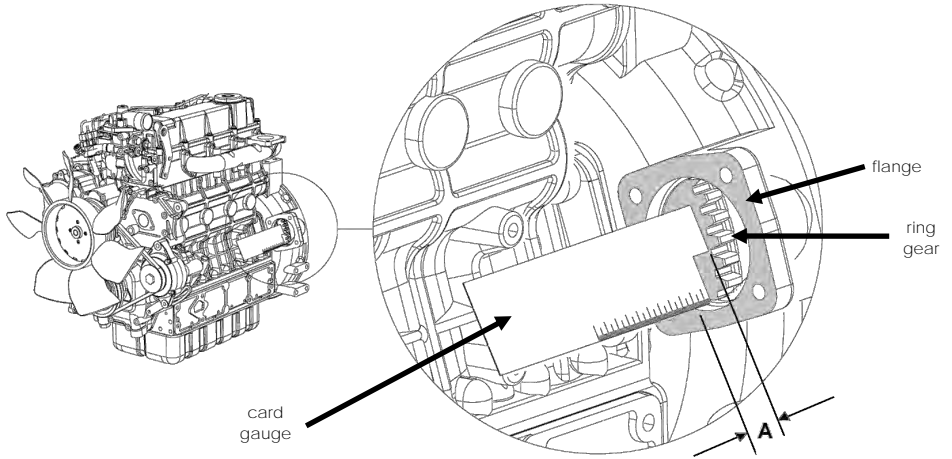

- d. Make sure the spring starter's pinion is as far back into the starter body as it can go, known as the 'pinion at rest' position
- e. Measure the 'pinion at rest' dimension B, as shown in Fig 3iii, making sure any spacers are fitted to the starter flange face if supplied with the spring starter

Fig 3iii

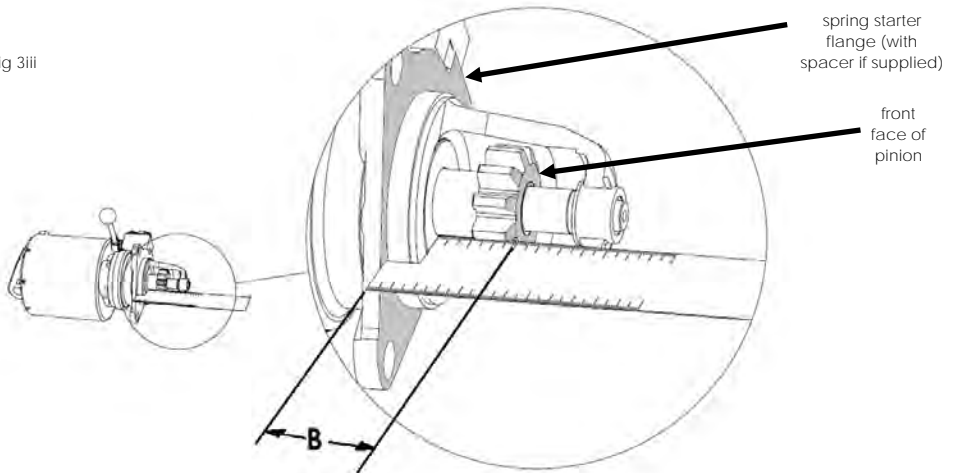



- f. Then,  $A-B=C$ , where C is the clearance between the pinion and ring gear. This should be between 3 to 5mm

The last pre-installation check ensures the pinion will not hit the flywheel when fully extended. (This is only necessary on engines with a flywheel that has a shoulder of larger diameter than the root diameter of the ring gear.)

- g. Use the card gauge to measure from the front face of the ring gear to the shoulder of the flywheel, dimension D, as shown in Fig 3iv

Fig 3iv

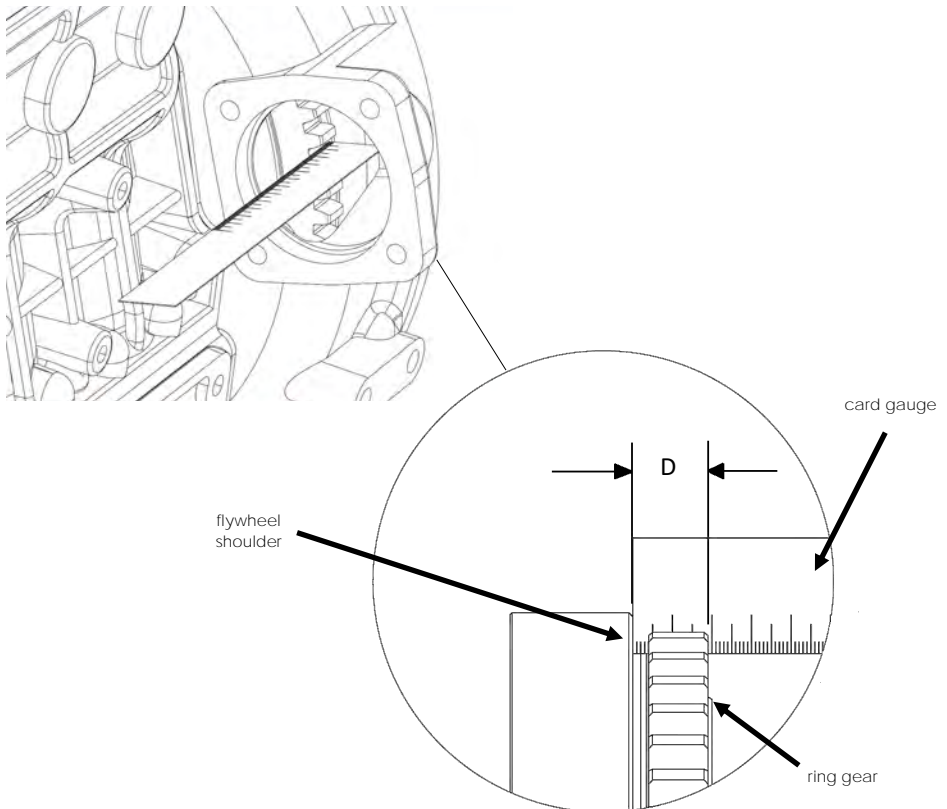

- h. Then,  $C+D=E$ , where E must be greater than 20mm, as this is the distance that the pinion will travel forward when engaged in the ring gear

## 5. Fitting the Spring Starter

The next steps check that the spring starter fits onto the engine. The starter will be mounted to the engine in this step but DO NOT attempt to start the engine. The starter will be removed from the engine after this step.

- a. Mount the spring starter into the pocket (not forgetting to include any spacers supplied with the spring starter) as shown in Fig 4i using existing studs and nuts torqued to the engine manufacturer's specifications. Kineteco do not supply these studs or nuts

Fig 4i

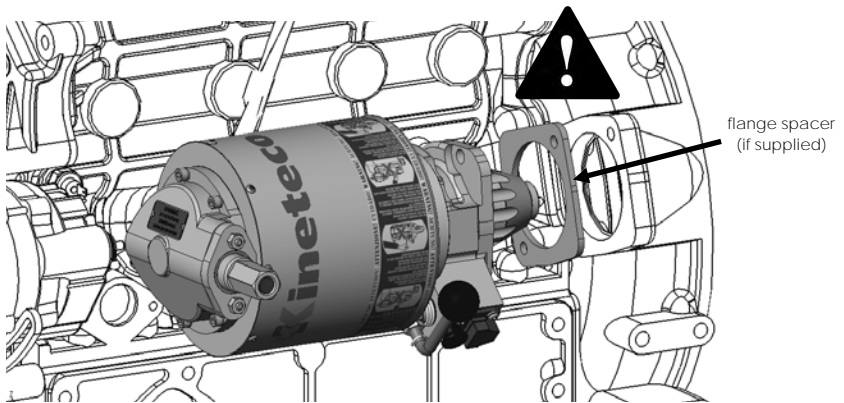

- b. Ensure the spring starter flange face sits flat on the mounting plate and is not jammed at an angle against the engine block, by passing a piece of paper between the spring starter and the engine block, Fig 4ii. Fig 4iii shows a correctly installed starter

Fig 4ii

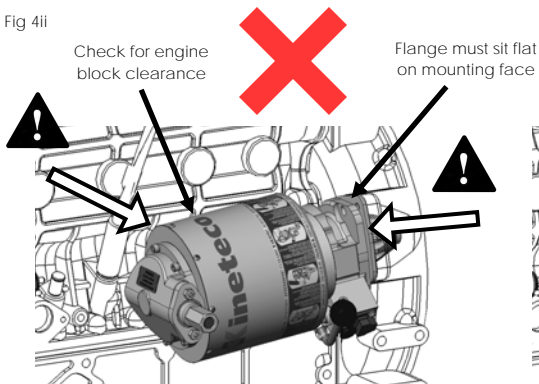
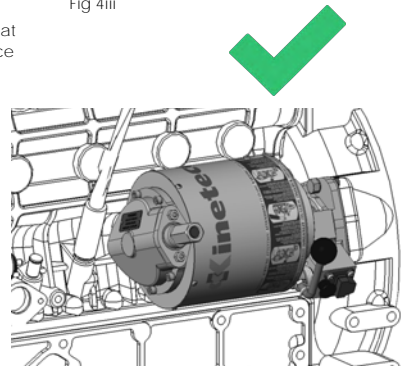

Fig 4iii



## 6. Engine 'Walk Over' to Check Pinion Engagement

This procedure ensures the pinion teeth engage correctly with the engine's ring gear so that starting will be smooth and excessive wear will not occur.

- a. Disconnect the battery negative lead, if electrical starting system is present, and ensure the engine is out of gear
- b. RESET the spring starter:
  1. Lift the release pin with one hand holding the trip lever with the other, Fig 5i
  2. Pull the trip lever up against the spring force, Fig 5ii
  3. Let go of release pin and the trip lever will click and lock in vertical position, Fig 5iii

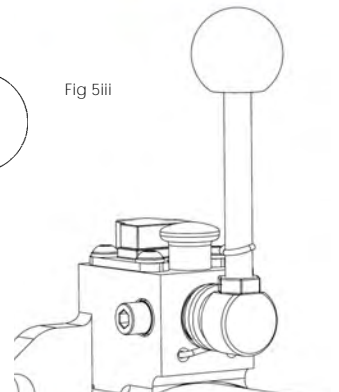
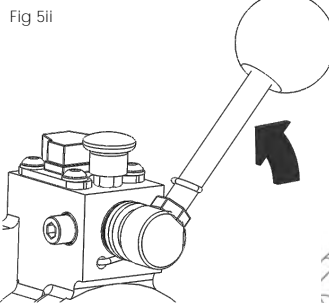
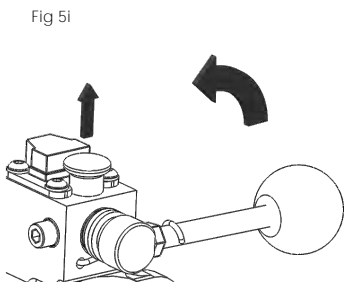
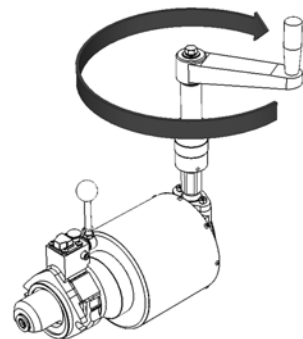

Fig 5iv

- c. Fit the winding handle onto the winding adaptor and wind **CLOCKWISE THREE TURNS** only, Fig 5iv. This will pre-engage the pinion. When it is engaged an increase in winding load should be detectable



d. TRIP the spring starter:

- Grasp the trip lever in one hand and lift the release pin with the other, Fig 5v
- Push lever firmly across 90 degrees, Fig 5vi
- Let go of release pin and the trip lever will lock in horizontal position as shown, Fig 5vii

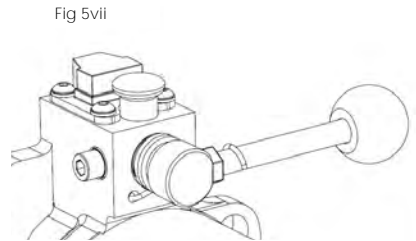
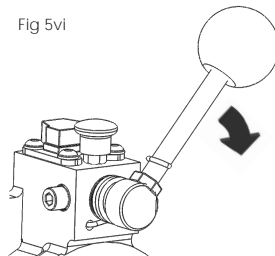
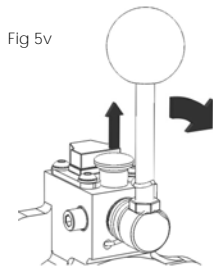

e. Continue winding the handle CLOCKWISE, which should now be turning the engine over

f. Ensure there are no tight spots in the pinion to ring gear mesh by making a complete revolution of the ring gear in this fashion

g. Disengage the pinion by unwinding the starter. This is done by winding the handle ANTI-CLOCKWISE for at least 3 turns, Fig 5viii. (An increase in effort will be needed to begin with. During unwinding no ratchet click will be heard)

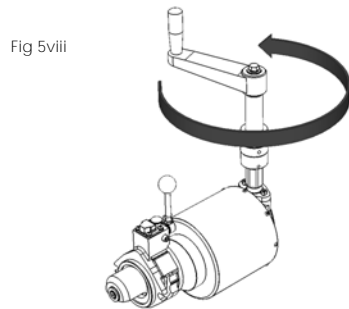

h. Dismount the spring starter from the engine and inspect the pinion teeth. Engagement is correct if witness/wear marks show across at least 75% of the driven surface of the gear tooth, Fig 5ix

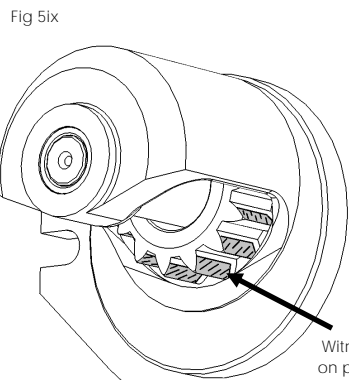

If the starter engages correctly, remount the starter and continue to the next section of this handbook. If all the instructions have been followed and the starter does not engage as specified, please contact Kineteco for further guidance.

## 7. Spring Starting for the First Time

The starter may now be operated but only under a minimal load for the initial operations. Starting under full charge can reduce the spring life and is not always necessary. Follow these steps the first time you attempt to start the engine with the spring starter

- a. Ensure all steps prior to this page in the handbook have been carried out thoroughly
- b. Ensure that the engine and machinery are safely prepared for starting, including taking vehicles out of gear and cylinders are NOT decompressed



**WARNING**  
Do not use spring starter when engine is decompressed

- c. Check that the fuel tap is in the 'on' position, and that sufficient fuel is in the tank
- d. Position the throttle as per the engine manufacturer's instructions for starting. Most engines require at least a 3/4 open position
- e. RESET the spring starter
- f. Wind the starter CLOCKWISE fifteen rotations of the handle. You should be able to hear the winding ratchet clicking while you do this, if not, keep winding until you do and then count rotations
- g. Remove the winding handle from the winding adaptor, Fig 6



**WARNING**  
Always remove the winding handle before tripping the starter

Fig 6

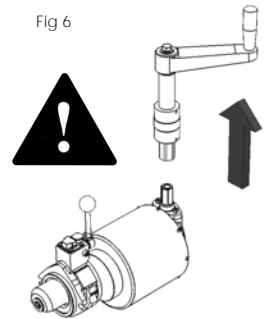

- h. Operate the engine's manual fuel lift pump (if fitted) to ensure good fuel supply to the engine
- i. TRIP the spring starter
- j. If the engine starts continue to step k. If not, wait for rotation to stop. Then return to step e, adding an extra handle rotation during winding. Continue to increase winding amount in this way by one rotation each trip until engine starts



**WARNING**  
DO NOT WIND STARTER MORE THAN 35 TURNS OF HANDLE

- k. When engine starts, adjust the throttle to the desired level
  - l. Make a note of the number of winds made when the engine started and mark on the quick reference operator's instructions label as the 'advised number of winds for starting'. Attach the label onto the equipment where the user will be able to refer to it
8. Standard Starting Procedure

Always take great care when operating your spring starter. Once the 'Spring Starting for the First Time' procedure has been followed, this standard procedure can be followed. The operator should have access to the quick reference operator's label as a reminder of this procedure in day-to-day use:

- a. Follow points a-k of the first-time starting procedure, using advised number of winds for starting as previously marked on quick ref. instructions
  - b. It is possible the engine does not start due to difference in climate or increased load at start-up. If this is the case, always allow the engine to come to a complete rest before retrying. Then increase number of wind rotations incrementally from the advised number of winds for each subsequent start attempt. Winding more than is necessary to start the engine will decrease the life of the springs. Never attempt to wind beyond 35 turns of the handle.
  - c. In cold weather (below 0°C) it may also be necessary to use a form of cold starting aid. **ONLY USE THE ENGINE MANUFACTURER'S RECOMMENDED/APPROVED COLD STARTING SYSTEM**
  - d. Once the engine has started, leave the trip lever in the TRIPPED position until the engine has stopped rotating and only RESET when the engine needs to be restarted by the spring starter
9. Unwinding the Spring Starter

It is possible to unwind the starter, should the need occur, by turning the handle ANTI-CLOCKWISE until the pinion has retracted from the engine's ring gear. Additional force will be required to overcome the initial friction in the winding assembly.



**WARNING**

Always make sure the starter is completely discharged before removing from engine

10. E-Pack Installation Instructions  
(Applicable to E- suffixed models only)

**WARNING**

Failure to install the spring starter correctly will invalidate the warranty

Kineteco recommend a spring starter fitted with our 'E-Pack' system, if intended for use in a dual starter installation, where the second starter is electric. This is only possible with engines featuring a flywheel housing with two starter pockets, and is a good option as backup if the electric starter option fails.

In this type of installation, the two starters should never be operated at the same time as this can cause damage to both starters and the engine itself. To ensure this is prevented Kineteco have introduced a unique 'E-Pack' safety system in which the electric starter is disabled if the spring starter is primed for use. Spring starters featuring an 'E-Pack' will have an 'E' suffix on the model number. This guide will show you how to install and check the functionality of this safety feature.

Your E-Pack spring starter will come fitted with a 3-core cable: green/yellow, blue and brown. The integrated switch should be used to interrupt the electric starter solenoid or starter switch power.

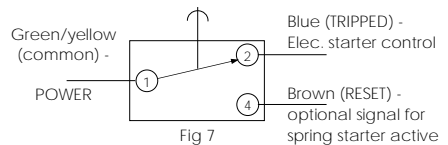

Circuit connections should be made as follows:

- With the spring starter in the TRIPPED position: ① - ② (electric starter solenoid/switch power active (state depicted in Fig 7))
- With the spring starter in the RESET position: ① - ④ (electric starter solenoid/switch power deactivated, can be used to indicate spring starter is in use, e.g., warning lamp)

NOTE: The integrated switch has a maximum 5A rating for 0-15VDC applications or 3A for 15-30 VDC, so should be used in conjunction with a relay if it is likely to see a load higher than this.

Once both the electric and spring starters have been installed and the wiring completed as instructed above, carry out the following test procedure:

- a. Make sure the spring starter is unwound so that the pinion is disengaged
- b. Position the lever into the RESET position, DO NOT wind the starter
- c. Attempt to start the engine with the electric starter. The electric starter should NOT function
- d. Move the lever into the TRIPPED position and test the electric starter again. The electric starter should run meaning the E-Pack circuit is functioning correctly. If not, check all wiring and re-run through test procedure

## 11. General Troubleshooting

If the engine does not start within three or four attempts, there are four possible explanations:

- a. Engine or fuel system is not primed for mechanical starting. Check engine set up as prescribed in the 'Operating Instructions' section of this guide. The engine must be purely mechanical, or a bypass in place for any ECU controlled fuel cut-out, for total black-start functionality.
- b. Incorrect method of starting. The throttle should be set between three quarters and fully open and the excess fuel device, if fitted, set to the excess fuel position. Make sure the fuel is 'up' and there is sufficient fuel in the tank. On cold engines, the starter will need to be wound further than when the engine is warm to start.
- c. Incorrect application. The engine may exceed the maximum capacity of the spring starter or may have ancillary equipment which could cause excessive drag. Contact Kineteco if you believe this to be the case so that an alternative spring starter can be offered.
- d. The spring starter may be faulty. If you believe the spring starter is in need of repair, please contact Kineteco. Our trained technical staff will be able to diagnose any problem and advise on the best course of action.



### WARNING

Never attempt to dismantle a spring starter yourself

This process requires specialised tooling and experience

Always contact your local Kineteco distributor to arrange repair



---

## **WARRANTY TERMS**

Hatraco B.V provides warranty repair for 12 months from the date of despatch. At our discretion, this may include complete replacement of the returned unit.

Warranty repair is subject to examination of the returned unit.

Detailed warranty conditions can be found on the Hatraco webpage : [www.hatraco.com/support](http://www.hatraco.com/support)

In case you wish to return a starter to the factory, please click and follow the applicable procedure and instructions.



Kineteco starters are the exclusive product of Hatraco BV and are manufactured in the Netherlands in accordance with CE guidelines and comply with the Machinery Directive.

#### DISCLAIMER

Whilst every care has been taken in compiling this publication, Hatraco B.V. cannot accept responsibility for any inaccuracies. Hatraco B.V. has an ongoing programme of design and development which may well alter product specifications. Hatraco BV reserve the right to alter specifications without notice and whenever necessary to ensure optimum performance from its product

#### ALL RIGHTS RESERVED

All content, including but not limited to text, graphics, logos, and images, is the property of Hatraco BV and is protected by international copyright laws. The Kineteco trademark and all related intellectual property are the exclusive property of Hatraco BV. Unauthorized use, reproduction, or distribution of any material from this document without prior written consent from Hatraco BV is strictly prohibited. Any infringement of these rights will be pursued to the fullest extent of the law.



Version 3  
(Updated 24-01-2025)

Hatraco BV  
De Koppeling 3  
6986 CS Angerlo  
the Netherlands  
Tel: +31 (0)316 280191

Website: [www.springstarter.com](http://www.springstarter.com)  
Website: [www.hatraco.com](http://www.hatraco.com)  
E-mail: [sales@hatraco.com](mailto:sales@hatraco.com)